

3"R W/LG. PILOT  
(3) PLC'S

2" B. W/C.I. PLUG  
INSPECTION OPENING  
(2) PLC'S

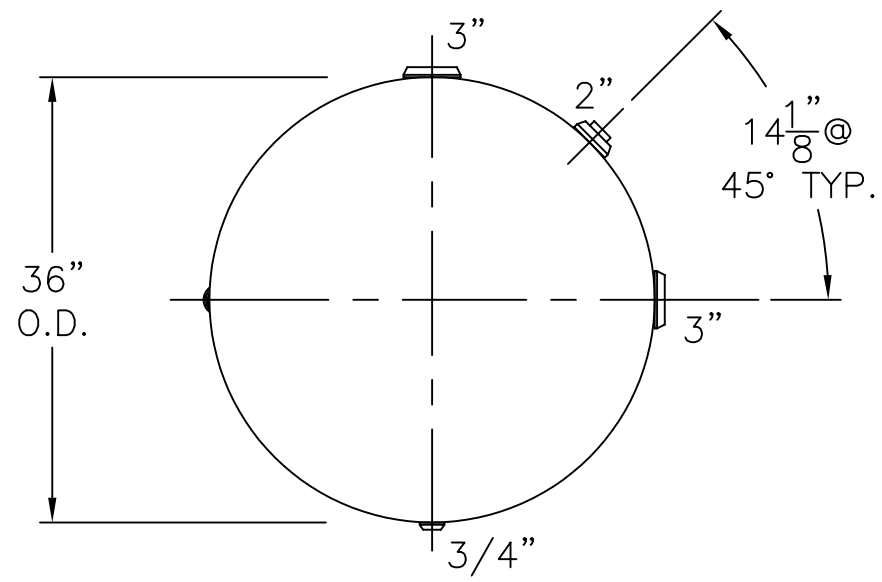
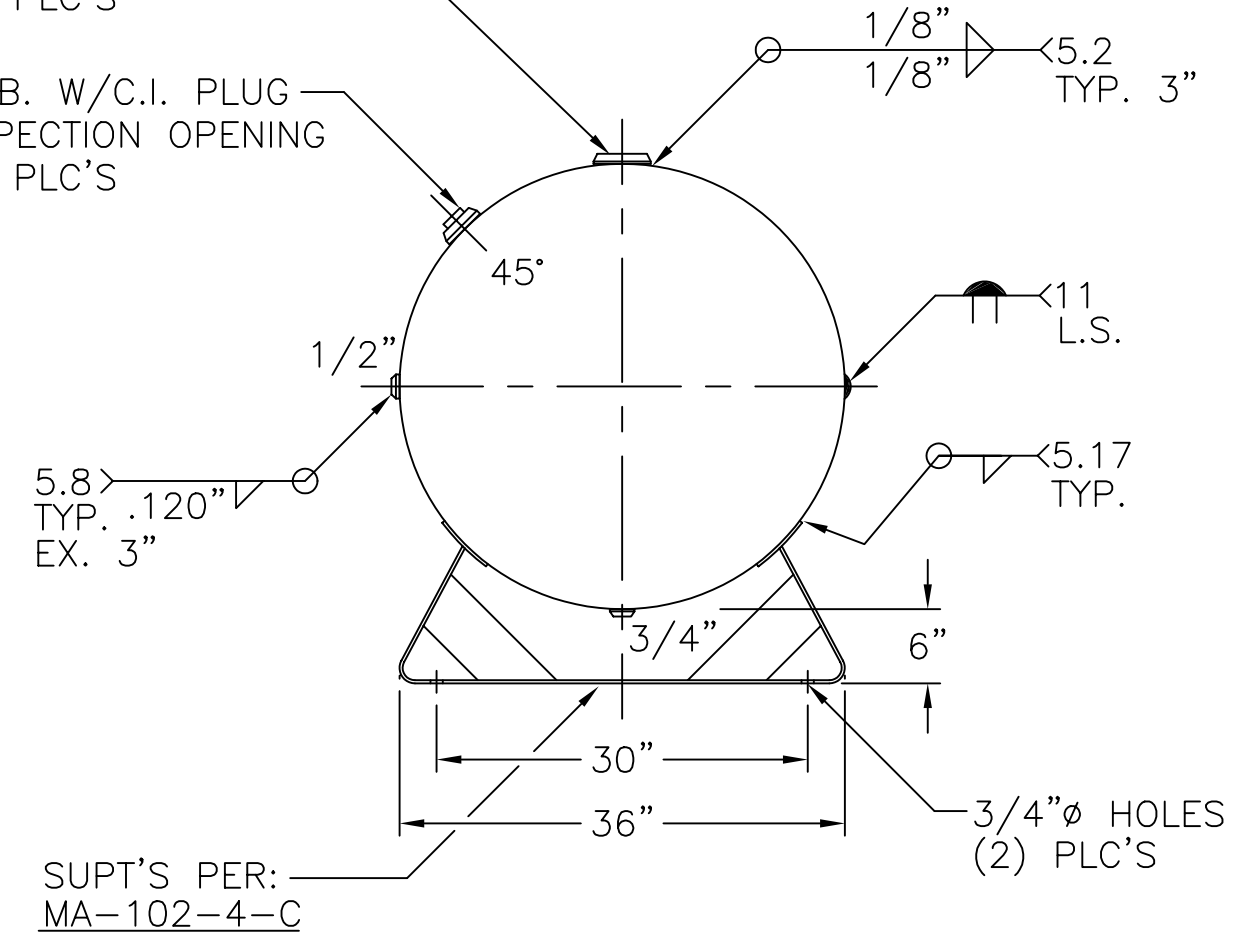

VIEW W/OUT TOP SUPT'S

3) CRN - ALBERTA #T5898.2  
2) IMPACT TESTED? NO UG-20 (f)  
NOTE: 1) HYDRO @ 262 PSIG. MIN.

HEADS	.210" SA-455 2:1 S.E.	36-HA-500-W	REV. 3-2-06
	JOGGLE - .209 OFFSET		DATE: 4-23-99
SHELL	.199"MIN. SA-455	FOR: HANSON STANDARD	
		HORIZ. AIR TANK	
M.A.W.P. 200 PSIG. @ 400 °F		INSIDE: UNPAINTED	
M.D.M.T. -20 °F @ 200 PSIG.		OUTSIDE: PRIME	
ASME SECTION VIII DIV. 1, 2004 ADD 2005		CAD-"B" SIZE UNDER "STD"-SERIES	
X-RAY: RT-4 SPOT L.S. ONLY		BY: J.G.	SCALE: 3/4"=12"
GALLONS: 500		WT. 936 LBS.	
SERIAL NO.		<b>ROY E. HANSON JR. MFG.</b>	
		1924 COMPTON AVE. LOS ANGELES, CA 90011	