

2"R W/ C.I. PLUG  
INSP. OPENING  
(2) PLC'S.

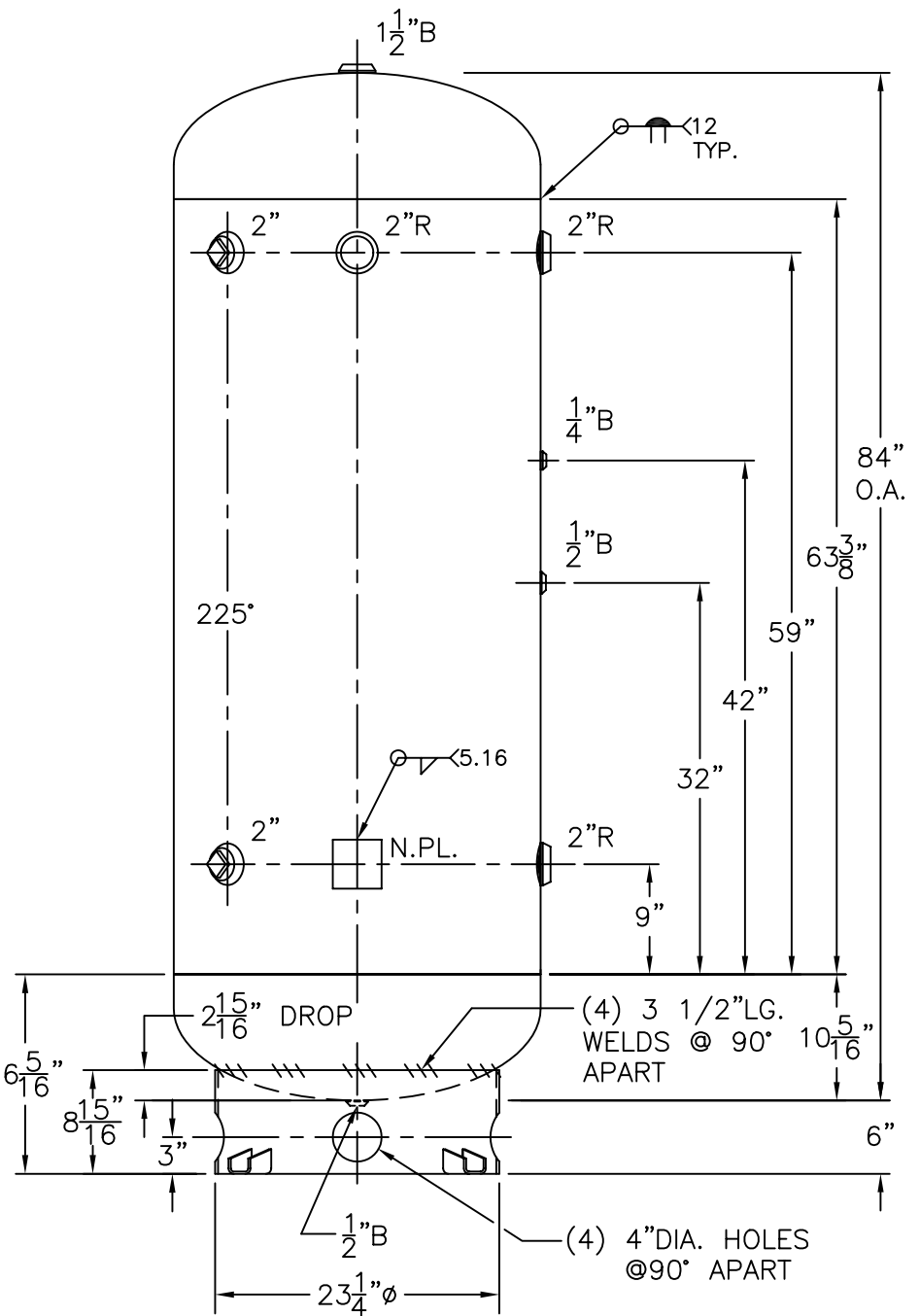

NOTE: 1) HYDRO @ 327 PSIG. MIN.

SHELL / HEADS	
.218" SA-455	2:1 S.E.
JOGGLE (.205" MIN.)	
.209 OFFSET	
.218" SA-455	
(.206" MIN.)	
M.A.W.P.	250 PSIG. @ 400 °F
M.D.M.T.	-20 °F @ 250 PSIG.
ASME SECTION VIII	DIV. 1, 2004 ADD 2006
X-RAY: RT-4 SPOT L.S. ONLY	
GALLONS: 240	WT. 591 LBS.
SERIAL NO.	
N.B.	

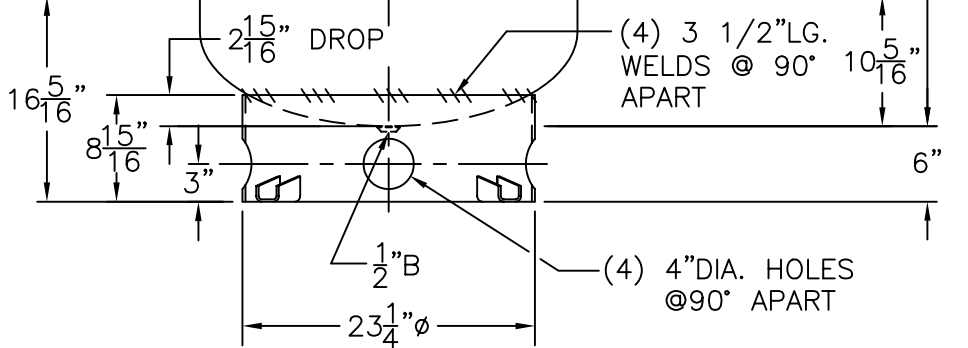

3/16" THK. CLIPS PER  
MA-395-B (4) PLC'S  
W 9/16" Ø HOLE ON  
26 3/8" B.C.; WELD OUTSIDE  
VERT. EDGE OF CLIP ONLY

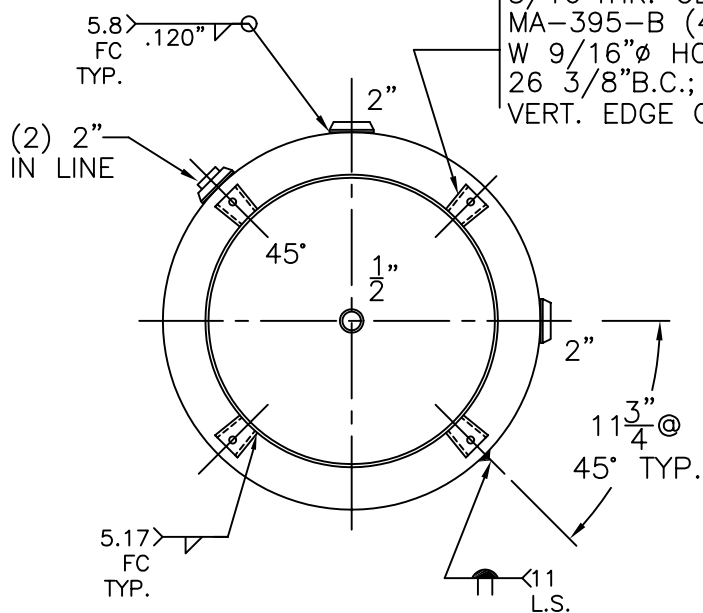

<b>30-VC-240-R</b>	REV. 8-28-07
FOR: HANSON STANDARD	DATE: 12-2-86
VERT. AIR TANK	
INSIDE: UNPAINTED	
OUTSIDE: PRIME	
BY: J.G.	SCALE: 3/4" = 12"
<b>ROY F. HANSON JR. MFG.</b>	
1600 E. WASHINGTON BLVD.	
LOS ANGELES, CA 90021	