

3/16" THK. CLIPS PER
 MA-395-B (4) PLC'S.
 W/ 9/16" ϕ HOLE ON
 26 3/8" B.C.; WELD OUTSIDE
 VERT. EDGE OF CLIP ONLY

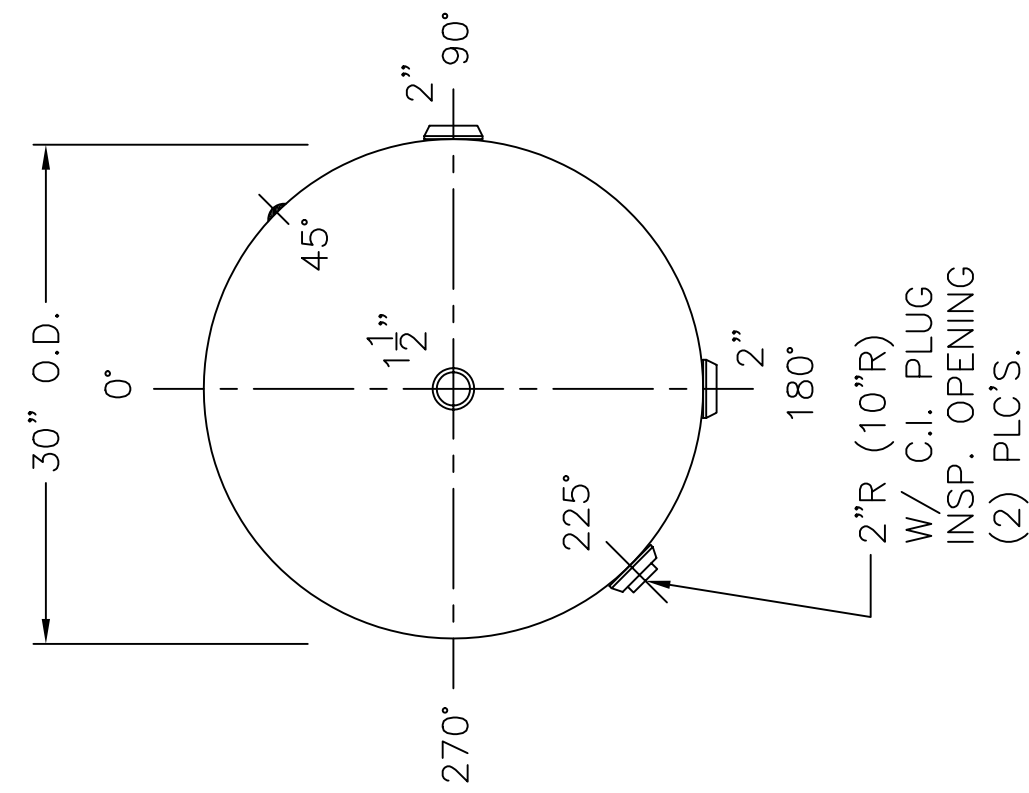
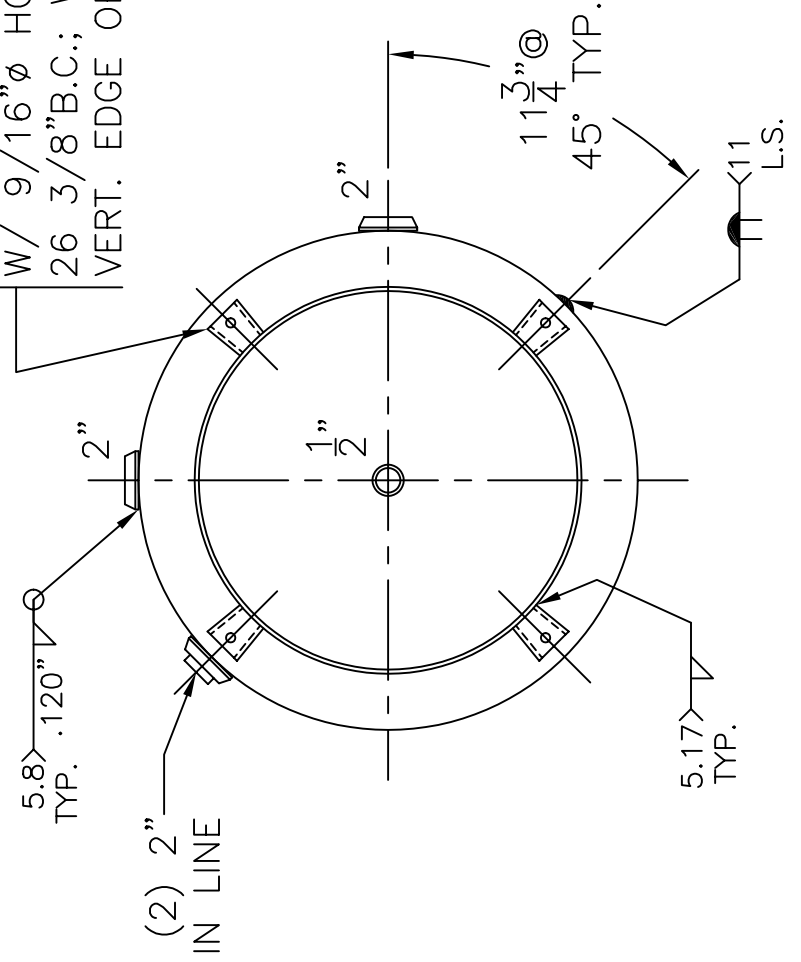

NOTE: 1) HYDRO @ 262 PSIG. MIN.

SHELL / HEADS	.166" SA-414-G 2:1 S.E.	30-VA-200-R	REV. 6-4-07
	(.164" MIN.) JOGGLE		DATE: 11-24-86
	.149" OFFSET	FOR: HANSON STANDARD	
	.165 SA-414-G	VERT. AIR TANK	
		INSIDE: UNPAINTED	
		OUTSIDE: PRIME	
M.A.W.P. 200 PSIG. @ 400 °F		BY: E.S.	SCALE: 3/4"=12"
M.D.M.T. -20 °F @ 200 PSIG.		ROY E. HANSON JR. MFG.	
ASME. SECTION VIII DIV. 1, 2004 ADD 2006		1600 E. WASHINGTON BLVD.	
X-RAY: RT-4 SPOT L.S.		LOS ANGELES, CA 90021	
GALLONS: 200	WT. 380 LBS.		
SERIAL NO.			
N.B.			